



## Soil and Weather Monitoring System with Crop Prediction for Farmers Using IoT and Machine Learning

---

Velmurugan Sathya Narayanan, Kavin N Raj, Kishore Kumar and Manoj Kumar

EasyChair preprints are intended for rapid dissemination of research results and are integrated with the rest of EasyChair.

October 22, 2021

# SOIL AND WEATHER MONITORING SYSTEM WITH CROP PREDICTION FOR FARMERS USING IOT AND MACHINE LEARNING

V.Sathya Narayanan<sup>1</sup>, Kavinraj N<sup>2</sup>, Kishore Kumar S<sup>3</sup>, Manoj Kumar K<sup>4</sup>

<sup>1</sup>Assitant Professor

<sup>2,3,4</sup>U.G students

*Electronics and Communication Engineering,  
Kongu Engineering College, Erode,  
Tamil Nadu.*

[sathyanarayanan@kongu.ac.in](mailto:sathyanarayanan@kongu.ac.in), [kavinrajn.17ece@kongu.edu](mailto:kavinrajn.17ece@kongu.edu),

[kishorekumars.17ece@kongu.edu](mailto:kishorekumars.17ece@kongu.edu), [manojkumark.17ece@kongu.edu](mailto:manojkumark.17ece@kongu.edu)

**ABSTRACT** - Smart agro farm is a low-priced cost soil and weather observing system which analyses the various soil characteristics and the weather thereby developing a hi-tech smart farm equipment for farmers. The existing system is not much cost-effective smart irrigation systems, hence the proposed project is aimed to develop a cost-effective Smart Irrigation system. This system consists of two main modules named as soil and weather monitoring module where we can implement the smart irrigation system and machine learning module. First module composes of circuit interconnections and characterization of various soil sensors. Soil moisture is detected by using Soil moisture sensor. The temperature and humidity can be found out by DHT 11 (Digital Humidity Temperature). The second module ( Machine Learning ), that deals with extracting the information from all the above data values gathered from sensor. An android application is developed which provides proper awareness and guidance regarding the cultivation of preferable crops to farmers. Hence, our system is the perfect combination of IoT, Machine Learning and Android Application. Also it is useful for low-income household farmers to intensify into smart climate farming practice. The simulation shows that the Proposed system achieves 98.1818 % of accuracy which out performs the existing state of technique.

**Keywords :** IOT, Machine Learning, Sensors, Mobile application, Random Forest algorithm

## 1. INTRODUCTION

From ancient days, agriculture has been carried out in South-Asian countries in a complete manual process. Technologies are developed for economical use of water for irrigation purpose sensible agro farm- a soil and weather observation system for farmers may be a came upon developed for farmers for correct observation and gathering of crops and provides better decision

relating to that crop are going to be cultivated underneath acceptable climate conditions. Web or Internet of Things (IoT) is an advanced technology for observation and operating the device anywhere within the world. It will connect devices with living things. Web of Things is creating a big mark in several fields. Nowadays, the accommodative nature of IoT has reworked, will be utilised by a normal user. Many methodologies that IoT has developed created man's life easier more comfortable like sensible education, cities, e-health sector and automation. In India, the farmers are facing difficulties in forecasting the weather and crops based on climate data. In recent years the advancement of Machine Learning plays a crucial role in every field including agriculture, here the crop prediction process done with consolidating the preceding data and the present data of the various sensors connected with IoT. The proposed system analyzes the application of supervised machine learning approaches the class with the very best chance is taken into account as the possibly class. Here the category is nothing however the crop that get foretold for the given input parameters. Once the crop is foretold, it will facilitate the farmers to predict the affordable crop for their individual land. Then, the farmers is guided with an application in mobile tend to make them to understand that what quite seeds we will tend to sow in land to induce higher yielding. Within the past preceding data, crop prediction was calculated by analyzing farmer's previous expertise on climatic condition. So, the correct data regarding history of climatic condition is a vital factor for creating selections in choosing crops. Therefore, this paper proposes a thought to predict the affordable crop for the given input parameter for the poor farmers using machine learning. Thereby this proposed work will suggest the farmers with effective solutions for more profitable cultivation.

## **2. LITERATURE SURVEY**

Devi Devapal (2020) ., "Smart Agro Farm Solar Powered Soil and Weather Monitoring System for Farmers"Proceedings 24 (2020) 1843–1854 ,SCIENCE DIRECT Smart agro farm may be a low price solar power-driven soil and weather monitoring system that analyses the various soil properties and climate and thereby developing a high-tech smart system farm , for farmers. this method consists of 3 main modules entitled as IoT module, machine learning module and mobile application module. The IoT module includes of circuit interconnections and characterization variety soil sensors for finding soil wet or moisture that itself or automatically utilizes alternative energy for the functioning and thus providing a lot of affordability to farmers. because the input for K-means cluster may be a methodology of vector division, originally from signal process, that's common for cluster analysis in machine learning.K-means cluster aims to partition n observations into k clusters during which every observation belongs to the cluster with the closest mean, serving as a example of the cluster.

Renuka & Sujata Terdal, "Evaluation of Machine Learning Algorithms for Crop Prediction", Volume 177, October 2020, 105709, SCIENCE DIRECT, Agriculture plays a major role within the growth of the national economy. It relay on weather and different environmental aspects. a number

of the factors on that agriculture relies area unit Soil, climate, flooding, fertilizers, temperature, precipitation, crops, pesticides and herb. The crop yield relies on these factors and therefore tough to predict. to understand the standing of crop production, during this work we tend to perform descriptive study on agricultural information mistreatment numerous machine learning techniques. Crop yield estimates embrace estimating crop yields from accessible historical information like precipitation information, soil data, and historic crop yields.

J. C. Augusto, M. Quinde, J. G. Giménez Manuel, S. M. M. Ali, C. L. Oguego and C. James-Reynolds, "The SEArch Smart Environments Architecture," 2019 15th International Conference on Intelligent Environments (IE), Rabat, Morocco, 2019. Sensing technology has become one vital enabler and stimulating supply of innovation in ICT, computing and technology with social impact [1,2]. world and business have recently made a large variety of systems supported the idea of “smart technologies”, suggesting the potential to collect precise discourse info through sensing, supports more practical decision-making. abundant of those developments square measure alpha as a number of these technologies square measure still recent and not as reliable as fascinating. several of those environments square measure engineering in nature, systems and strategies square measure being developed bottom up and there square measure an absence of methodologies and alternative community resources that act as standards or a minimum of as guides of excellent apply.

V. Puranik, Sharmila, A. Ranjan and A. Kumari, "Automation in Agriculture and IoT," 2019 4th International Conference on Internet of Things: Smart Innovation and Usages (IoT- SIU), Ghaziabad, India, 2019. We live during a world of digitisation. Almost everything around us is bit by conversion. The role the Technology should play in agriculture sector is changing into additional and additional visible day by day. Since year of its beginning communication has played a crucial half in agriculture, it was not simply restricted to in area of crop medical specialty however it's played polar role within the modification ancient previous agricultural practices. One may witness development in varied methodologies and technologies being employed within the agricultural system. On the contrary, the agriculture sector in Asian nation is witnessing losing ground a day that has affected the production capability of the system. there's associate rising want to solve the matter within the said domain to revive vibrancy and put it back on higher growth.

Arun Kumar & et al ., “Efficient Crop Yield Prediction Using Machine Learning Algorithms” , Volume: 05 Issue: 06 | June-2019,International Research Journal of Engineering and Technology (IRJET) Descriptive analytics is that the initial state of analytics. it's a method during which we will understand what happened within the past. And we know that past is that the best predictor of the longer term. during this analysis paper we tend to apply descriptive analytics within the agriculture production domain for sugarcane crop to search out economical crop yield estimation. during this paper we've got 3 datasets like as Soil dataset, precipitation dataset, and Yield dataset. on this combined dataset we apply many supervised techniques to search out the particular calculable

price and also the accuracy of many techniques. during this paper 3 supervised techniques are used like as K-Nearest Neighbor, Support Vector Machine, and Least square Support Vector Machine.

Nithin Singh & saurabh chaturvedi , “Weather forecasting using machine learning”, 2019 International Conference on Signal Processing and Communication (ICSC) The activities of the many primary sectors depend on the weather for production, e.g. farming. The climate is dynamical at a drastic rate today, that makes the previous weather prediction ways less effective and additional hectic. to beat these difficulties, the improved and reliable weather prediction ways area unit needed. These predictions have an effect on a nation's economy and therefore the lives of individuals. To develop a meteorology system which will be utilized in remote areas is that the main motivation of this work.

Ramesh Medar & Anand M. Ambekar, “Sugarcane Crop prediction Using Supervised Machine Learning” , Published Online August 2019 in MECS. Traditionally, application of LTTS within the agriculture sector for yield prediction/crop statement is limited to empirical strategies exploitation ground-based observations and productions reports gathered by numerous organizations from completely different sources: meteorologic information, agro- meteorological(yield), soil (water holding capacity), and remotely perceived agricultural statistics. Based on the scientific discipline information, many indices they are derived that are deemed to be related variables in finding crop yield. as an example, crop water satisfaction, surplus and excess wet, average soil moisture.

Andrew Crane Droesch , “Machine learning methods for crop yield prediction and climate change impact assessment in agriculture” , 26 October 2019(IRJET) Crop yields are critically passionate about weather. A growing empirical literature models this relationship so as to project temperature change impacts on the world. we have a tendency to describe an approach to yield modeling that uses a semiparametric variant of a deep neural network, which might at the same time account for advanced nonlinear relationships in high-dimensional datasets, yet as identified constant quantity structure and unobserved cross-sectional nonuniformity. exploitation information on corn yield from the us midwest, we have a tendency to show that this approach outperforms each classical statistical strategies and fully- nonparametric neural networks in predicting yields of years withheld throughout model.

### **3. EXISTING SYSTEM**

In the field of real time monitoring the temperature and humidity of soil and other factor like monitoring of conditions like weather, wind direction, wind speed, water level, flood. monitoring, automated irrigation facility and providing alarming system that's warning alarm to farmer's phone when certain condition occurs supported Wireless Farming System can correctly guide agricultural production and improve crop yield. It has been assumed that yield rate in an agricultural isn't

improving. Soil moisture is that the water stored within the soil and is suffering from precipitation, temperature, soil characteristics, and more. It have a many node but each node includes temperature, humidity, soil moisture and water level sensors as well as microcontroller and relay switching unit. The Plenty of research work has been done to improve the performance of agriculture field the system uses technology to control watering and roofing of the green house. It uses statistical data acquired from sensors (like temperature, humidity, moisture and intensity of light intensity sensors) compared with the weather outlook for making decision.

### **3.1 DISADVANTAGES**

1. The existing system does not having any mobile application to predict the crop for the particular field
2. It requires evaluation of site specific conditions that is before selection of appropriate moisture sensor.
3. It requires human power or labor to collect the data and maintain the measurement processes.
4. The measured values or readings depend on properties of various soil conditions and materials. The correct interpretation and use of moisture data is required .
5. Watermark sensors is providing less accuracy within sandy soils due to large number of particles.
6. Watermark sensors are required to be calibrated for every soil types.

## **4. PROPOSED SYSTEM**

Internet of Things (IoT) is nothing but it is an advanced technology for the live monitoring and controlling device anywhere in the world. We are going to develop a system that can help in an automated irrigation system by analyzing the moisture level of the ground. The crop prediction process done with consolidating the preceding data and the present data of the various sensors connected with IoT. Machine learning may be a methodology of analyzing information to automatize the given model. Within the past preceding data, crop prediction was calculated by analyzing farmer's previous expertise on climatic condition. Finally, Android application is developed which provides proper awareness and guidance regarding the cultivation of preferable crops to farmers. Hence, our system is perfect combination of IoT, machine learning and Android Application. Finally, mobile android application is developed that provides correct awareness and steering guidance the cultivation of preferred crops to farmers. Hence, our system is ideal combination of IoT, machine learning and android application. additionally it welcomes low-income home farmers to accentuate into good climate farming practice.

## 4.1 BLOCK DIAGRAM

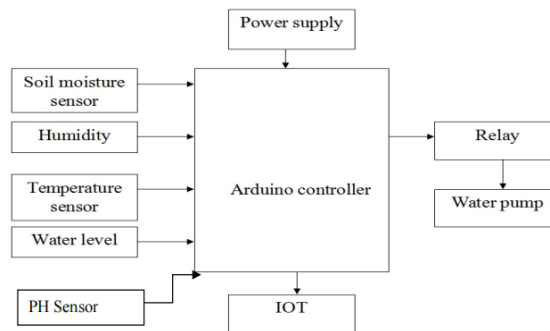

Fig 4.1 BLOCK DIAGRAM

The planned system is Arduino primarily based automation for optimizing utilization of water resources and reducing labour value in agricultural applications. System consists of arduino platform and useful elements like moisture device & motor load and proposed block diagram shown in the figure 4.1. Arduino could be a single board elements hardware and IDE code interface for playing automation operations. moisture device detects the humidness level of soil. Soil moisture and temperature planned vary is about significantly for specific plants demand, and in keeping with that system is being operated. Motor load includes water pumps and concerned accessories for provision water to plants. Atmega328 Microcontroller automates water cycle supported data collected from humidness and temperature device. If soil moisture level is a smaller amount than minimum outlined threshold price, microcontroller acts to automatically trigger pump to work until device meets most threshold. A threshold value is about at the start of the procedure .The steps before fixing the threshold price are as follows :

- The soil moisture device is buried within the soil and also the flow of water is opened a minimum of one inch of water is allowed to face on the soil.
- The soil is left beneath the sun for twenty four hours. If it rains during this interval the procedure needs to be started from the start.
- The moisture reading is noted at the tip of twenty four hours and with fifth deviation from the wetness reading, the threshold values are set.

The data is gathered and compared o the threshold reading. after the comparison, If the wetness content is higher than the threshold value then once a delay of a predefined time the value is scan once more and compared. If the wetness content is a smaller amount than the threshold reading, then the system bypasses one circle of reading the values. Signal is shipped to the pump to give notice a few phase change ( From LOW to HIGH) Valve for the actual strip during which the wetness content is a smaller amount than the threshold reading is opened and water from the pump is allowed to flow.

## **5. METHODOLOGY**

### **5.1 SOIL AND WEATHER MONITORING SYSTEM WITH SMART IRRIGATION**

IoT based irrigation system works by the various values of sensors on Arduino kit. Firstly depending on need of crop a threshold value is set on moisture sensor. The humidity is read by the sensor continuously and checked with the threshold value. If humidity value is less than threshold then still irrigation is continued. When the threshold value is obtained then the motor is turned off automatically by the signals sent through Arduino kit. Arduino microcontroller board has been connected with water pump through. Soil moisture sensors are connected with Arduino to get readings of moisture of soil. With the values collected from the various sensors are compared with the threshold values thus operation can be switched. The principle of Soil Moisture Sensors is Dielectric permittivity. We know that dielectric permittivity is directly proportional and it will tell the amount of water present in the soil. Soil Moisture Sensors are connected at the other end to the Arduino chipset. Those values were sent to the Arduino kit and also displayed on the system using LCD. The data is gathered and compared to the threshold reading. After the comparison, if the wetness content is higher than the threshold value then once a delay of a predefined time the value is scanned once more and compared. If the wetness content is a smaller amount than the threshold reading, then the system bypasses one cycle of reading the values. Signal is shipped to the pump to give notice a few phase change (From LOW to HIGH) Valve for the actual strip during which the wetness content is a smaller amount than the threshold reading is opened and water from the pump is allowed to flow.

#### **5.1.1 ADVANTAGES**

- Smart irrigation system can improve crop quality and yield with the help of sensing parameters like, soil moisture, air temperature, humidity and water level of the tank.
- The system will continuously monitor water level of the tank via water level sensor so that if water level is below bottom then irrigation will not be started.
- Remote monitoring and controlling avoids human intervention. Reduction in water consumption reduces the power consumption and cost.

### **5.2 CROP PREDICTION USING MACHINE LEARNING**

In recent years the advancement of Machine Learning plays a crucial role in every field including agriculture, here the crop prediction process done with consolidating the preceding data and the present data of the various sensors connected with IoT. The proposed system is described in



following stages such as dataset collection, preprocessing step, feature selection and applying machine learning modules. It is shown in the figure 5.1

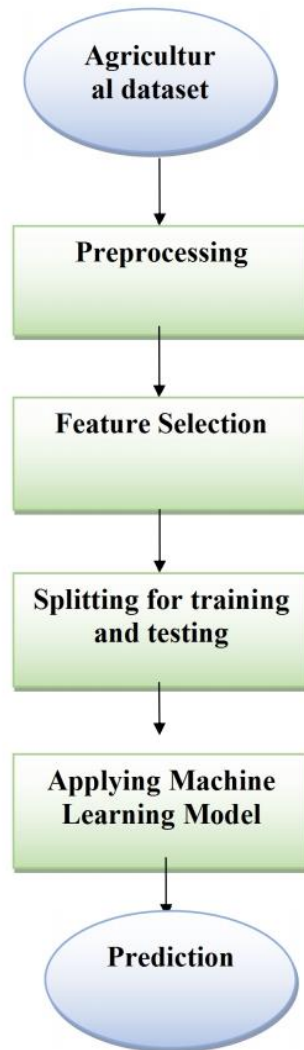

**FIG 5.1** STAGES OF MACHINE LEARNING

### **5.2.1 DATASET COLLECTION**

Data is collected from a variety of sources and prepared for data sets. And this data is used for descriptive analysis. Data is available from several online abstract sources like data.gov.in. We will use an annual summary of crops for at least 10 years. The data sets used in this paper are soil dataset, rainfall dataset, temperature, humidity, and crop data. It is shown in the figure 5.2

	temperat	humidity	ph	rainfall	label
2	20.87974	82.00274	6.502985	202.9355	rice
3	21.77046	80.31964	7.038096	226.6555	rice
4	23.00446	82.32076	7.840207	263.9642	rice
5	26.4911	80.15836	6.980401	242.864	rice
6	20.13017	81.60487	7.628473	262.7173	rice
7	23.05805	83.37012	7.073454	251.055	rice
8	22.70884	82.63941	5.700806	271.3249	rice
9	20.27774	82.89409	5.718627	241.9742	rice
10	24.51588	83.53522	6.685346	230.4462	rice
11	23.22397	83.03323	6.336254	221.2092	rice
12	26.52724	81.41754	5.386168	264.6149	rice
13	23.97898	81.45062	7.502834	250.0832	rice
14	26.8008	80.88685	5.108682	284.4365	rice
15	24.01498	82.05687	6.984354	185.2773	rice
16	25.66585	80.66385	6.94802	209.587	rice
17	24.28209	80.30026	7.042299	231.0863	rice
18	21.58712	82.78837	6.249051	276.6552	rice
19	23.79392	80.41818	6.97086	206.2612	rice
20	21.86525	80.1923	5.953933	224.555	rice
21	23.57944	83.5876	5.853932	291.2987	rice
22	21.32504	80.47476	6.442475	185.4975	rice
23	25.15746	83.11713	5.070176	231.3843	rice

**Fig 5.2 DATASET**

### 5.2.2 PREPROCESSING STEP

This step is a very important step in machine learning. Preprocessing consists of inserting the missing values, the appropriate data range, and extracting the functionality. The kind of the dataset is critical to the analysis process. In this paper we have used `isnull()` method for checking null values and `Label Encoder()` for converting the categorical data into numerical data.

### 5.2.3 FEATURE SELECTION

Feature extraction should simplify the amount of data involved to represent a large data set. The soil and crop characteristics extracted from the pre-treatment phase constitute the final set of training. These characteristics include the physical and chemical properties of the soil. Here, we have used `Random Forest Classifier()` method for feature selection. This method selects the features based on the entropy value i.e., the attribute which is having more entropy value is selected as important feature for yield prediction.

### 5.2.4 SPLIT THE DATASET INTO TRAIN AND TEST SET

This step includes coaching and testing of input file. The loaded dataset is split into 2 sets, like train dataset and testing dataset, with a division ratios of 80 percentage or 20 percentage, such as 0.8 or 0.2. In learning set, a classifier used to make the obtainable input dataset. During this step, produce the classifier's support dataset and preconceptions to approximate and classify the operate. Throughout the testing section, the dataset is tested. The ultimate data is created throughout preprocessing and is processed by the machine learning module.

### 5.3 APPLYING MACHINE LEARNING MODEL

This model used a complete of 5 Machine Learning algorithms for training and testing the prepared dataset. These 5 algorithms were supervised algorithms which will do binary classification. In our project we've got used `Random forest` algorithmic rule, because the name says it's it is combo of number of decision making trees and an ensemble classification model. `Random forest` model collects trained dataset from all the tree nodes and separates the weaker nodes train dataset to induce higher predictions. We are able to do both the classification and regression issues by using `RF` model.

### **5.3.1 LOGISTIC REGRESSION**

This algorithm uses a regression model to find the best-fitting model that describes a dependent variable based on a set of independent variables. The outcomes of the dependent variable consist of only two possible values: true or false. Therefore it is well suited for binary classifications.

### **5.3.2 NAÏVE BAYES**

This algorithm uses a probability calculation of Bayes' theorem. Each independent variable contributes to the probability of the outcome. It is a powerful knowledge representation and reasoning algorithm under conditions of uncertainty.

### **5.3.3 SUPPORT VECTOR MACHINE**

This algorithm finds the optimum hyperplane that separates two classes with the maximum distance between the border points of each class. These border points form the support vector. Therefore it is effective for high-dimensional space problems, and is memory efficient. However if the feature count is larger than the number of samples, this technique will have only a mediocre performance.

### **5.3.4 DECISION TREE**

This algorithm uses a tree structure analogy to represent a series of rules that lead to a class or value. It starts with a root node, which is the best predictor. Then, it progresses through branch nodes to other predictors. Ultimately it reaches the leaf nodes, which represent a decision or classification.

### **5.3.5 RANDOM FOREST**

This algorithm is similar to BT, where multiple small trees are built. However, it differs in the way it calculates the final predictive outcome. Instead of using a boosting method, it uses a bagging method. This method uses the mean of the individual small trees to obtain the final predictive outcome. This classifier is found to be fast and efficient with large datasets.

## **5.3 MOBILE APPLICATION MODULE**

In the Mobile Application module initially the output of the information mining algorithmic program is passed on to a webpage that is additional connected with associate android app. Within the Webpage, the user will register and login to understand the crop predictions of a specific space using the information collected from the sensors. The android app is developed by using Java code,

PHP, HTML. The implementation is finished by the installation of Heroku, There were many steps to implement Heroku. We tend to deploy it by employing a PHP app. Firstly, we tend to produce and use free tier account of Heroku. Secondly, we are going to perform PHP installation, that is employed to run Heroku on localhost. Managing Heroku needs instruction Interface (CLI). Therefore, we've to put in its command line interface first. It serves to manage application, stipulation add-ons, etc. helps run the appliance locally. once we tend to covert our online page to android application. Mobile application is associate open-source, Linux-based software for mobile devices like smart phones and smart computers. mobile application was developed by the Open telephone Alliance, led by Google, and alternative corporations. mobile application programming is predicated on Java programing language. Within the Mobile Application module initial the output of the information mining algorithm is passed on to a webpage that is additional connected with associate android app. Home page contains associate icons in it specifically Crop Prediction purpose. Every icon contains its own options. By clicking the prediction icon, it'll predict the crop that's which is suitable to cultivate on the given farm.

## **6. SOFTWARE REQUIREMENTS**

### **6.1 PROJECT DISCRPTION**

The existing system that's about to be represented during this part is completed using the Proteus model. To to induce the required output, the simulation circuit has been designed in Proteus software system by use the various parts that's present within the Proteus. This simulation circuit are described in detailed below.

### **6.2 PROTEUS SOFTWARE DISCRPTION**

This chapter describes the real design and current implementation of the Proteus dependableness manager and object works. the appliance requirements and also the kind of aqua applications that they are presently supported by Proteus are represented. The gateway, are also a part of Proteus.

### **6.3 The PROTEUS Environment**

Proteus PIC is the complete solution for developing a system, testing and virtually prototyping your embedded system designs based around the Microchip Technologies of microcontroller. It is shown in the figure 6.1. This software allows you to perform schematic capture and you can able to simulate the circuits that you design. A demonstration on the use of PROTEUS will be given to you, after that you are encouraged to learn to use the software interactively.

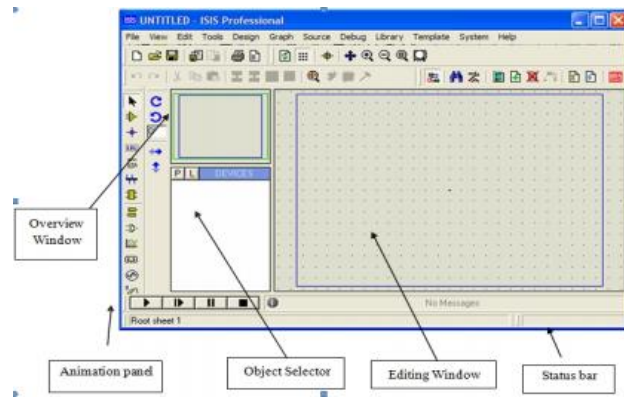

**Fig 6.1** Proteus IDE

Type ' PIC16F877A ' in the Key words field to search or insert and made a double click on the result to place the PIC16F877A in Object Selector. Repeat the same process for the LED, Buttons, Crystal oscillator, capacitors, 7 SEG-COM- Cathode, Resistors. Once you have selected all components into the design then close the Library Browser and left click when any component in the Object Selector . Now made a left click on the Editing Window to make sure to place the component on the schematic - repeat the process to all components on the schematic.

#### **6.4 ARDUINO IDE**

It is an open-source software. It is shown in the figure 6.2. It is mainly used for writing and compiling the code. The code is compiled into the module. The code is done in an official Arduino software. The code compilation is very easy. It is available for many operating systems. They are MAC, Windows, and Linux. It runs in java platform. It comes with the inbuilt functions. Debugging, editing and compiling is done in the Arduino Ide. Different types of modules are available. They are Arduino Mega, Leonardo, Micro and many more. They contain a microcontroller on the board, it is programmed in the c programming. The code is created on IDE platform. A Hex file will be created. It can be transferred and uploaded in the Arduino compiler. The IDE has two basic parts. They are Editor and Compiler. The compiler is used for compiling and uploading the code. It supports both C and C++ languages. The IDE environment is mainly divided into three sections. They are

- Menu Bar
- Text Editor
- Output Pane

Menu Bar is defined as the bar appearing on the top is called as Menu Bar. The check mark is in the circular button. After writing the code, it is used to check. Once the code is written, it is used to verify it. The arrow key is used to upload. In order to create a new code, the dotted paper is used. There are two types of arrow present in the Arduino. One is upward arrow and the other one is downward arrow. The upward arrow is used to open an existing project. The downward arrow is

used to save the code which is currently going on. On the top right, there will be available of serial monitor. It is used to debug the code. The Arduino module is connected to the computer using Cable, in order to activate it. The baud rate should be selected before performing the coding operations. The Arduino baud rate is 9600. Arduino C language is similar to the C language. It can be used for any embedded system microcontroller.

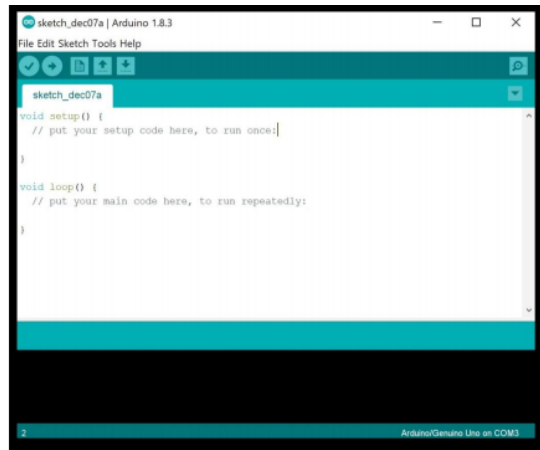

**Figure 6.2** IDE Environment

Libraries will be very useful for adding the extra functions. The libraries can be added by selecting the sketch button. The sketch button will be available in the menu bar. After adding the necessary libraries, it will be included with the #include sign. Most of the libraries will be preinstalled. Some of the libraries can download from the external sources. The code can be directly burn in the controller. It is done with the help of bootloader. It can buy from outside but it should be installed.

## 6.4 HEROKU CLOUD

Heroku, as a cloud platform as a service (PaaS), supports some programming languages. It is one of the cloud platforms that have been developed since 2007. It is shown in the figure 6.3. It is based on a managed container system with integrated data service and more powerful ecosystem to develop and run modern apps. Develop Heroku is an integration of tools and developer tools. Heroku runs on Dynos app. Dynos are the heart of the Heroku platform. Dynos makes it easy to develop and run apps more flexible and measurable. Dynos also make it easy to manage the infrastructure, so it can be used to run great apps. With Heroku, developers can build system using the programming languages that they like. Heroku supports some programming languages like Java, PHP, Python, Ruby, Go, Scala, and Clojure<sup>32</sup>



**Fig 6.3** HEROKU APPLICATION DEVELOPMENT

Android programming is predicated on Java programming language within the Mobile Application module first the output of the info mining algorithm is passed on to a webpage which is further connected with an android app. PHP: Hypertext Pre-processor (or simply PHP) could also be a general-purpose programming language originally designed for web development. The PHP reference implementation is now produced by The PHP Group. PHP originally stood for private Home Page, but it now stands for the recursive initialism PHP: Hypertext Pre-processor. It is a server side scripting language is employed for general purpose programming language .PHP Scripts are even executed on the server . It can generate the dynamic page content. It can create, open, read, write, delete and shut the files on the server, it also can add, delay, modify data in your database. it's compatible with most the servers used today. PHP code could also be executed with a instruction interface (CLI), embedded into HTML code, or it are often utilized in combination with various web template systems, web page management systems, and web frameworks. PHP code is usually processed by a PHP interpreter implemented as a module during an internet server or as a typical Gateway Interface (CGI) executable. The online server used to combines the results of the various interpreted files and executed PHP code, which can be any sort of data, including images, with the generated website . PHP are often used for several programming tasks outside of the online context, like standalone graphical applications and robotic drone control. The PHP language introduced without a written formal specification or standard till 2014, with the first implementation acting because of the standard which other implementations aimed to follow. Since 2014, work has went to form the correct PHP specification.

<b>Hardware</b>	Intel(R) Core(TM)i5-6500 CPU Memory 8 GB System type 64 Bit
<b>Software</b>	Operating system: Windows 10 Cloud: Heroku <a href="https://www.heroku.com/">https://www.heroku.com/</a> Local Host: Laragon Programming Language : HTML + PHP

**FIG 6.4 HARDWARE REQUIREMENT**

## **7. RESULT AND DESCRIPTION**

### **7.1 SOIL AND WEATHER MONITORING SYSTEM WITH SMART IRRIGATION**

The soil moisture sensors is used and they are allowed to read the moisture content of the soil in every fixed interval of time. The data is gathered and compared o the threshold value. After the comparison, If the moisture content is more than the threshold value then after a delay of a fixed time the value is read again and compared. The monitored data compared with threshold value. After the comparision, if the moisture content is more than the threshold values then, the arduino sends a signal to stop the motor. In another case if the moisture content is less than the threshold values then, the arduino sends a signal to start the motor. The hardware setup is shown in the figure 7.1

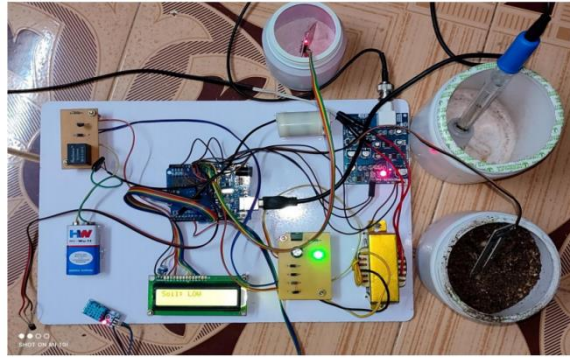

**FIG 7.1 HARDWARE SETUP**

The proposed system is also having a web application to monitor the particular agricultural environment and here we can see the various sensor output and weather conditions and these values are taken for crop prediction. The web application environment is shown in the figure 7.2



**FIG 7.2 WEB APPLICATION FOR MONITORING**

## **7.2 CROP RECOMMENDATION SYSTEM**

### **7.2.1 HEAT MAP**

A heatmap nothing but it is a representation of graph or graphical in nature where individual values of a matrix are represented as colors. It is shown in the figure 7.3. A heatmap is useful in graphical visualizing the concentration of values between two dimensions of a matrix . This helps gives a perspective of depth and in finding patterns . Heatmaps makes a good starting point for more sophisticated analysis. But it is like eye-catching visualization technique, making it a useful tool for communication. Here, we've cropped the dataset into a smaller set to made it easy to view, understand and compare with some of these bins. Each bin is annotated with underlying values now,



which makes it easy to compare them. The Diagonal and off-diagonal cells corresponds to accurately and inappropriately classified observations.

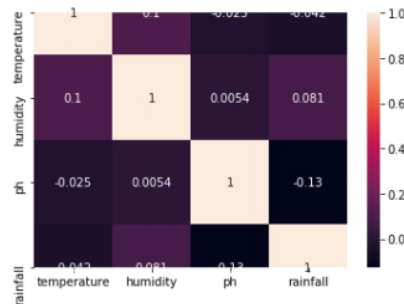

**Fig 7.3 Heat Map**

### 7.2.2 ROC CHARACTERISTICS

ROC curve depicts us the performance of a classifier with over all possible thresholds and a user can select suitable threshold value for the algorithm. It is shown in the figure 7.4. ROC curve can be generated by plotting a true positive rate along the y-axis against a false positive rate along the x-axis. It is a graph that is used to infer the performance of different machine learning models. This graph is plotted between false positive and true positive rates where true positive is totally positive and false positive is a total negative. The area under the curve (AUC) summarises when we talk about its ability to generalize how good a model is. Receiver operating characteristics is utilised to validate quality of classifiers. For each class in classifier ROC applies the threshold values to output and for each of the threshold values, two values were calculated and they are true positive and false positive. True positive rate is an outcome where our model how perfectly predicts the positive class or the output whom real and analysed class separated by the output whose class is predicted.

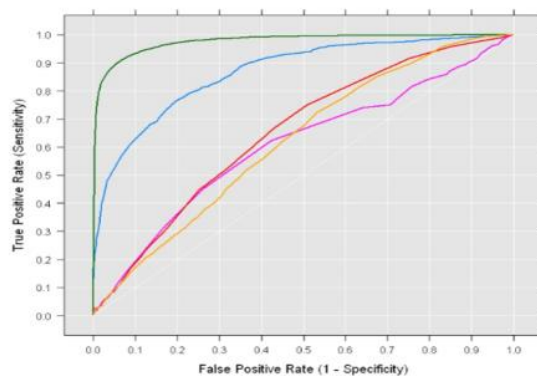

**Fig 7.4 ROC Characteristics**

### 7.2.3 ACCURACY COMPARISON

We used various Machine Learning algorithms, and their results are shown in Table 7.1. Random forest produced the highest accuracy of 98.1818% while comparing with Gaussian naïve bayes, Decision Tree, Support Vector Machine, Logistic Regression.

### True Positive Rate (TPR)

This metric calculates how often the model is able to predict a positive result correctly. Similar to Accuracy, but difference is it only takes positive observation.

It is given by ,  $TPR = TP/(TP+FN)$ .

### False Alarm Rate (FAR)

This metric calculates how often the model is predicting a positive result wrongly. It provides indication of possible error of the model, thus lower value is better. It is given by ,  $FAR = FP/(FP+TN)$ .

### Accuracy

This metric determines the accuracy, all correct prediction, of the model. It is the model abilities to predict both positive and negative results correctly. It is given by ,  $ACCURACY = TN+TP/(TN+TP+FP+FN)$

**TABLE 7.1** Accuracy Comparison Table

ALGORITHM	ACCURACY (%)	TPR (%)	FAR (%)
Random Forest (Proposed algorithm)	98.1818	98.17	0.02
Naive Bayes (Existing algorithm)	95.9090	95.92	0.27
Decision Tree	84.7727	88.84	0.24
SVM	77.9545	77.96	31.92
Logistic Regression	75.9090	82.72	32.63

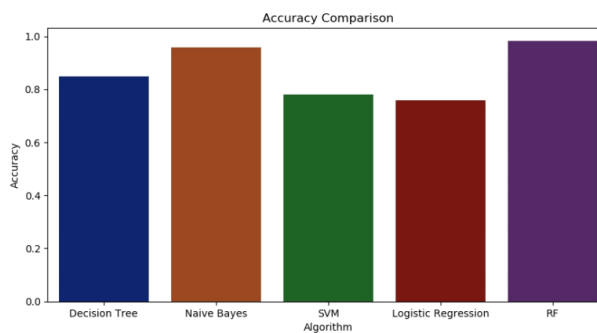

**Fig 7.5** Accuracy Comparison Chart

From the above mentioned comparison Fig 7.5 shows Random Forest Regression Algorithm gives 98.1818% while comparing with other algorithm. When comparing the Random Forest's accuracy with the other algorithm's accuracy in table 7.1 , Naive bayes comparatively 2.27% low like wise Decision Tree is 13.40% low, SVM is 20.22% low and finally, Logistic regression is 22.27% low.

## 7.2.4 ANDROID APPLICATION FOR CROP PREDICTION

In this project, we developed a Android Application that can provide a better suggestion to the farmers that which crop is suitable for their particular field. It is shown in the figure 7.6 and 7.7. In the crop recommendation application, the user can provide the soil data from their side like temperature, humidity, rainfall etc and the application will predict which crop should the user grow.

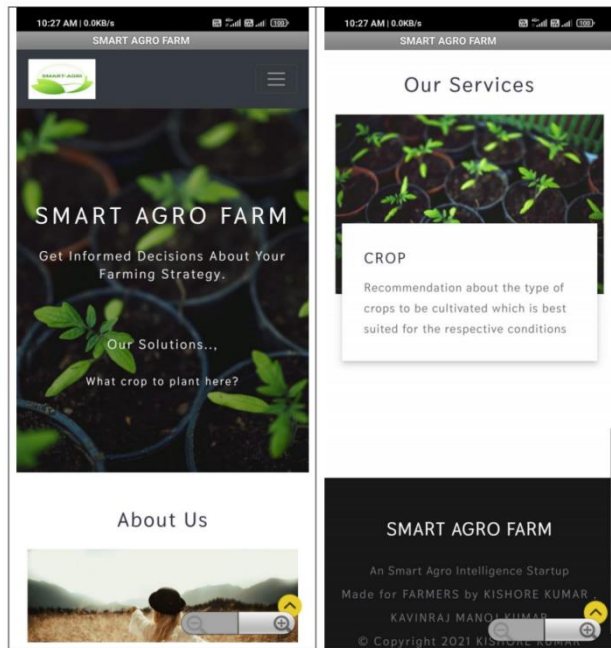

Fig 7.6 Home page of Android Application

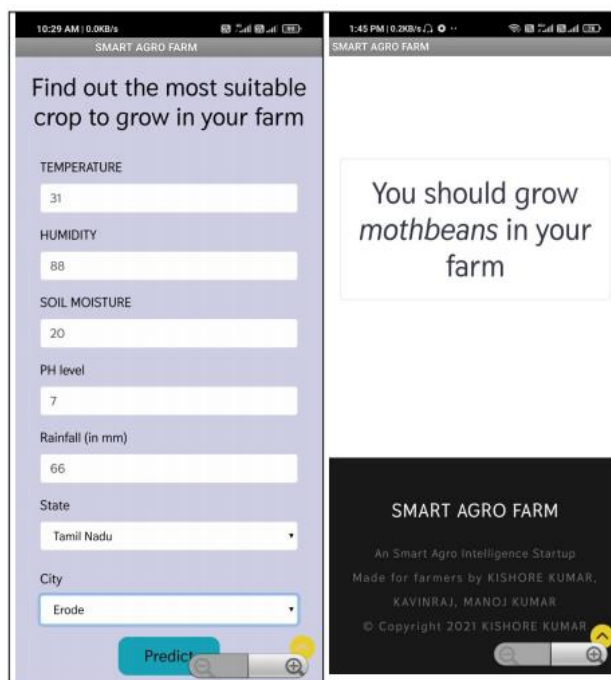

Fig 7.7 Prediction Page of Android Application

## 8. CONCLUSION AND FUTURE WORK

This system is mainly designed for developing a low cost soil and weather monitoring system which analyses the different soil properties and weather conditions and thereby developing a hi-tech smart farm set up for farmers. This project proposes an IoT based smart irrigation with soil and weather monitoring architecture along with a hybrid machine learning based approach to predict the suitable crop. The proposed algorithm uses sensors data of recent, past and the weather forecasted data for prediction of suitable crop using machine learning. This proposed system is used Random Forest algorithm for crop prediction and gives the accuracy about 98.1818% comparing with various algorithm. The developed mobile android application (SMART AGRO FARM) performs the prediction of crop using machine learning. Thus, this system is a perfect combination of IoT, Machine learning and Android Mobile Application. The proposed system, compare soil moisture, humidity, temperature to control amount and duration of watering the crops in the farm. This system used Random Forest Regression Algorithm and it gives accuracy about 98.1818% while comparing with other algorithm. Currently, This system can provide the prediction of suitable crop along with smart irrigation with soil and weather monitoring. In future, NPK (NITROGEN PHOSPHORUS POTASSIUM) sensor can be implemented to analyze the various crop nutrition to increase crop yield. By using Machine Learning this system can add a another system called crop nutrition analyze which can provide the various suggestion to farmers to increase the yield and this suggestion system can be added to same proposed android application .

## 9. REFERENCE

- [1] Devi Devapal ., “Smart Agro Farm Solar Powered Soil and Weather Monitoring System for Farmers”, Proceedings 24 (2020) 1843–1854 - IEEE XPLORE.
- [2] Renuka & Sujata Terdal, "Evaluation of Machine Learning Algorithms for Crop Prediction", Volume 177, October 2020, 105709, SCIENCE DIRECT.
- [3] J. C. Augusto, M. Quinde, J. G. Giménez Manuel, S. M. M. Ali, C. L. Oguego and C. James-Reynolds, "The SEArch SmartEnvironments Architecture," 2019 15th International Conference on Intelligent Environments (IE), Rabat, Morocco, 2019.
- [3] V. Puranik, Sharmila, A. Ranjan and A. Kumari, "Automation in Agriculture and IoT," 2019 4th International Conference on Internet of Things, Smart Innovation and Usages, Ghaziabad, India, 2019.
- [5] Arun Kumar & et al ., “Efficient Crop Yield Prediction Using Machine Learning Algorithms” , Volume: 05 Issue: 06 | June-2019, International Research Journal of Engineering and Technology (IRJET) .
- [6] Nithin Singh & saurabh chaturvedi , “Weather forecasting using machine learning”, 2019 International Conference on Signal Processing and Communication (ICSC)

- [7] Ramesh Medar & Anand M. Ambekar, “Sugarcane Crop prediction Using Supervised Machine Learning” , It is Published in Online August ( 2019 ) in MECS.
- [8] Andrew Crane Droesch , “Machine learning methods for crop yield prediction and climate change impact assessment in agriculture” , 26 October 2019(IRJET)
- [9] Vinita Shah & Prachi Shah , "Groundnut Prediction Using Machine Learning Techniques“ 2019 IJSRCSEIT | Volume 3 | Issue 5 | ISSN : 2456-330742
- [10] P. Vinciya, Dr. A. Valarmathi, “Agriculture Analysis for Next Generation High Tech Farming in Data Mining”, Volume 6, Issue 5, May 2019 ISSN: 2277 128X International Journal of Advanced Research in Computer Science and Software Engineering
- [11] Shivnath Ghosh,Santanu Koley (2019), “Machine Learning for Soil Fertility and Plant Nutrient Management using Back Propagation Neural Networks”, International Journal on Computer Science and Engineering, volume 2, issue 4, p. 1119 - 1121
- [12] Rajalakshmi.P, Mrs.S.Devi Mahalakshmi“*IOT Based Crop-Field Monitoring And Irrigation Automation*” 10th International conference on Intelligent systems and control (ISCO), 7-8 Jan 2016 published in IEEE Xplore Nov 2018.