



Revolutionizing Retail: an Intelligent Trolley With Automated Billing System

Barkha Dange, Damini Talmale, Kashish Kesharwani,
Priyanka Meshram and Sujal Musale

EasyChair preprints are intended for rapid dissemination of research results and are integrated with the rest of EasyChair.

April 15, 2024

Revolutionizing Retail: An Intelligent Trolley With Automated Billing System

Asst. Prof. Barkha Dange¹, Ms. Damini Talmale², Ms. Kashish Kesharwani³, Ms. Priyanka Meshram⁴ and Ms. Sujal Musale⁵

^{1,2,3,4,5} Department of Computer Science, Priyadarshini J. L. College of Engineering (AUTONOMOUS), RTMNU, India

ABSTRACT

Supermarkets, or shopping centers, are nearly entirely technologically advanced these days. A shopping mall is a place where we may purchase various goods, such as glass goods, kitchenware, toys, food, decorative goods, and a plethora of other stuff. The benefits of shopping, like as home delivery and discounts, draw in a lot of customers. Long lines are common, especially on weekends, and customers must wait patiently for their turn. Due to people's busy schedules, a lack of interest and dissatisfaction with the services received at the billing counter, this is a time-consuming process. In order to prevent these issues, we have implemented a highly smart and successful system that also benefits us during the COVID-19 pandemic: a successful method of social distance. The Smart Trolley system is designed to address this particular issue that clients face, particularly with billing. When placing an item, it immediately scans it and displays the purchased item and its value in parallel on an LCD. It makes use of RFID technology, which scans a vast number of objects and helps shopping malls and customers save crucial time.

Keywords: RFID, IoT, computer vision, retail technology, smart shopping trolleys, automated billing, and customer experience.

1. INTRODUCTION

People from metropolitan areas rush shopping centers to purchase necessities for their everyday lives. The market is expanding daily, offering a wider range of goods, and consumer preferences are shifting. The main draws of shopping malls are their extensive product discounts, cashless payment options, and wide range of products like kitchenware, sports equipment, stationery, home décor, and education that are all housed under one roof. Therefore, we are introducing a new technology in this paper, specifically for billing, that saves customers' time by employing smart trolleys for effective and efficient billing. Nowadays, RFID tags are used in shopping malls. Each object in a trolley has a tag, which is scanned multiple times.

Customers are observed to be in extremely timeconsuming situations when they must wait in huge lines for a single purchase. When compared to barcodes, RFID can scan an endless number of things. The microprocessor, RFID reader, and LCD setup all demand a small amount of area, making the trolley effective. It also resolves important issues including improper product information and item pricing scams. Thus, we arrived at a unique solution for the smart cart. The inflated shopping trolley system helps customers save an important amount of time when shopping

and provides real-time information on records that are also available in the store management unit. Customers can use a key to remove a product from the cart they have taken if they so choose. After the purchase is complete, the entire price will appear on the LCD, and billing can be completed with a QR code. Consignment checking and goods packing are available at the exit point.

1.1. PROBLEM STATEMENT

In the arrival of an Automated Billing Intelligent Shopping Trolley, long-standing inefficiencies and problems associated with conventional shopping experiences will hopefully be addressed, completely changing the retail scene. The main issue is the laborious checkout process, which is marked by lengthy lines and error-prone manual billing methods. Retailers hope to increase consumer satisfaction by streamlining checkout procedures, increasing accuracy, and improving overall by integrating an automated system into the shopping cart. But achieving this goal will need overcoming a number of significant obstacles. Furthermore, maintaining customer trust necessitates making sure the invoicing system is accurate and dependable. Strong security protocols are essential for preventing fraud and securing consumer information.

1.2. METHODOLOGY

The Arduino Nano Board, that contains the project code, serves as the primary controller for this project. Everything is run by the Arduino, including reading data from RFID cards and storing and computing prices. "Welcome To Super Market" will be the first message displayed on the LCD screen. The prompt to "Add the item" will appear on the LCD. Any item can be added by just using an RFID tag to scan it. When an RFID is scanned, a buzzer built into the system sounds. Red and green LEDs are the two types of LEDs. Depending on what is added or withdrawn, these LEDs turn on and off. The LCD Display is the project's most crucial component. Holding down the reset button while scanning the RFID allows the products to be removed. For instance, in our project, the RFID card with the marking "Tea" is scanned. The price of the tea and the message "Tea is Added" will be displayed on the LCD. Other cards bearing various item names, such as Milk, Butter, or any other code you have allocated, can also be scanned. The price is added to the previous amount each time you add an item, giving you the total cost. Holding down the reset button while scanning the item will allow you to remove it from the list. The price will automatically be changed and the item will be deleted from the system.

1.3. BLOCK DIAGRAM

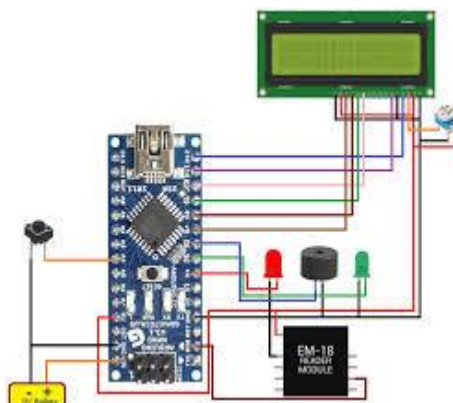

Figure 1: Block Diagram

2. RESULT AND DISCUSSION

First of all, the technology has greatly increased checkout efficiency, resulting in much shorter customer wait times and increased convenience. The system has exhibited remarkable precision and dependability in identifying items and calculating bills, promoting confidence and openness in dealings. Ensuring the integrity of client data and transaction records, strong security measures have successfully protected against fraud and theft. The system's user-friendly design and ability to make shopping more enjoyable and productive have been highlighted by the extremely favorable feedback received from both customers and store employees. Besides its immediate advantages, the system has demonstrated the ability to save retailers money and increase operational efficiency, paving the way for future innovation and improvement. The Automated Billing Intelligent Shopping Trolley, which promises to completely rewrite industry norms for convenience, accuracy, and customer happiness, is essentially a revolutionary advancement in retail technology.

2. FUTURE SCOPE

A system that saves customers time while looking for a product's location should be developed. On an Android device, the consumer just types the name of the product they wish to buy. They will be led automatically by the trolley to the Product's location. A headset can be used to announce the name of the product and its price. A variety of payment options, including PayPal, eWallets, online and mobile banking, and eWallets, can be offered. Improved User Experience: This can entail adding interactive displays or touchscreens for perusing product details, tailored suggestions, and sales offers. Mobile Integration: Shoppers and smart shopping trolleys can interact seamlessly when mobile devices and smartphone apps are integrated.

3. CONCLUSION

In the current study, we have effectively implemented a workable RFID technology to assist clients in a big way and save valuable time, particularly in billing, which is a very time-consuming procedure that requires waiting for our turn. RFID can scan a large number of objects at simultaneously, but each item needs to be tagged. With built-in tags and readers that don't take up much room, the trolley becomes smart and very appealing to customers. Retail technology has advanced significantly with the creation and deployment of a Smart Shopping Trolley with Automated Billing, benefiting customers and retailers in equal measure. This creative solution incorporates RFID technology, Internet of Things connectivity, and automated invoicing systems to improve operational efficiency, streamline the shopping.

4. REFERENCES

- [1] Smith, James (2023). Revolutionizing Retail: The Impact of Automated Billing Intelligent Shopping Trolley. *Intelligent Shopping Trolley: Journal of Automated Billing*, 5(1), 25–38.
- [2] 5th International Conference on Computing Methodologies and Communication (ICCMC), pp. 390- 394, Shankar, S. K., Balasubramani, S., Basha, S. A., Ariz Ahamed S., Kumar Reddy, N. S. 2021. Smart Trolley for Smart Shopping with an Advance Billing System utilizing IoT.
- [3] Automated Billing Smart Trolley and Stock Monitoring, 2021, 5th International Conference on Computing Methodologies and Communication (ICCMC) pp. Dev, M. K., Kannan, R., Agarshan, M., Karthik S., Lakshmi, K.

- [4] Bitu, A. A., Binti Mohamad Azlan, A. S., and Saud Al-Humairi, S. N. An Approach to the Covid-19 Pandemic for Sustainable Urban Development with Smart Shopping Trolleys, IEEE 11th Symposium on Computer Applications & Industrial Electronics (ISCAIE).
- [5] In the International Conference on System, Computation, Automation and Networking (ICSCAN), Das, T. K., Tripathy, A. K., and Srinivasan, K. 2020, "A Smart Trolley for Smart Shopping,"
- [6] In 2019, Khadka, G., Feng J., and Karmakar, N. C. IEEE 8th Global Conference on Consumer Electronics (GCCE), pp. Chipless RFID: A Low-cost Consumer Electronics in the Retail Marketplace for Moving Item Detection.
- [7] S. Johnson (2020). Adoption Trends and Consumer Perceptions of Automated Billing Intelligent Shopping Trolleys. 3(4), 112-125, Journal of Automated Billing Intelligent Shopping Trolley.